

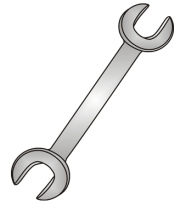

# Tow-Trust Towbars

Important: Please read General Notes overleaf before fitting



Issue 8

## TF169 FORD FOCUS 2 EST 2005 – 2011 FORD FOCUS 3 EST 2011>

Item	Qty	Description	Item	Qty	Description
A	1	Crossmember	F	2	M16 x 50 Bolts Nuts & S/P Washers
B	1	R/H Side Arm	G	4	M12 x 35 Bolts, 2 Nuts & 4 S/P Washers
C	1	L/H Side Arm	H	2	M12 x 85 Grade 10.9 Bolts & Nyloc Nuts
D	1	Extension bar	J	4	M10 Nuts & S/P Washers
E	2	Clamp Straps	K	4	10 x 25 Flat Washers
			L	4	12 x 25 Flat Washers
			M	2	16 x 27 Flat Washers

1. Remove the rear bumper. Two fixings along the top edge, two fixings along the lower face, two wheel arch liner screws and one nut each side behind the wheel arch liners.
2. Temporarily remove bumper beam.
3. Place Item E inside each chassis member and locate the captive bolts into the existing holes in the outside face of each chassis.
4. Using Item J with Item K loosely bolt Item B and Item C to the captive bolts.
5. Using Item G bolt Item A to Item B and Item C.
6. Fully tighten all nuts and bolts and ensure the Towbar is rigid and secure.
7. Replace bumper beam and bumper. **2011> Cut under tray to suit Towbar or hand back to customer so that vehicle can be brought back to standard if Towbar is removed.**
8. Using Item H with Item L bolt Item D to Item A.
9. Using Item F bolt the ball bracket and wiring plate (not supplied in this kit) to the mounting plate.  
Note: Item M may be required under the bolt head when not using PRO-TOW Couplings to ensure the bolt doesn't hit the bumper.

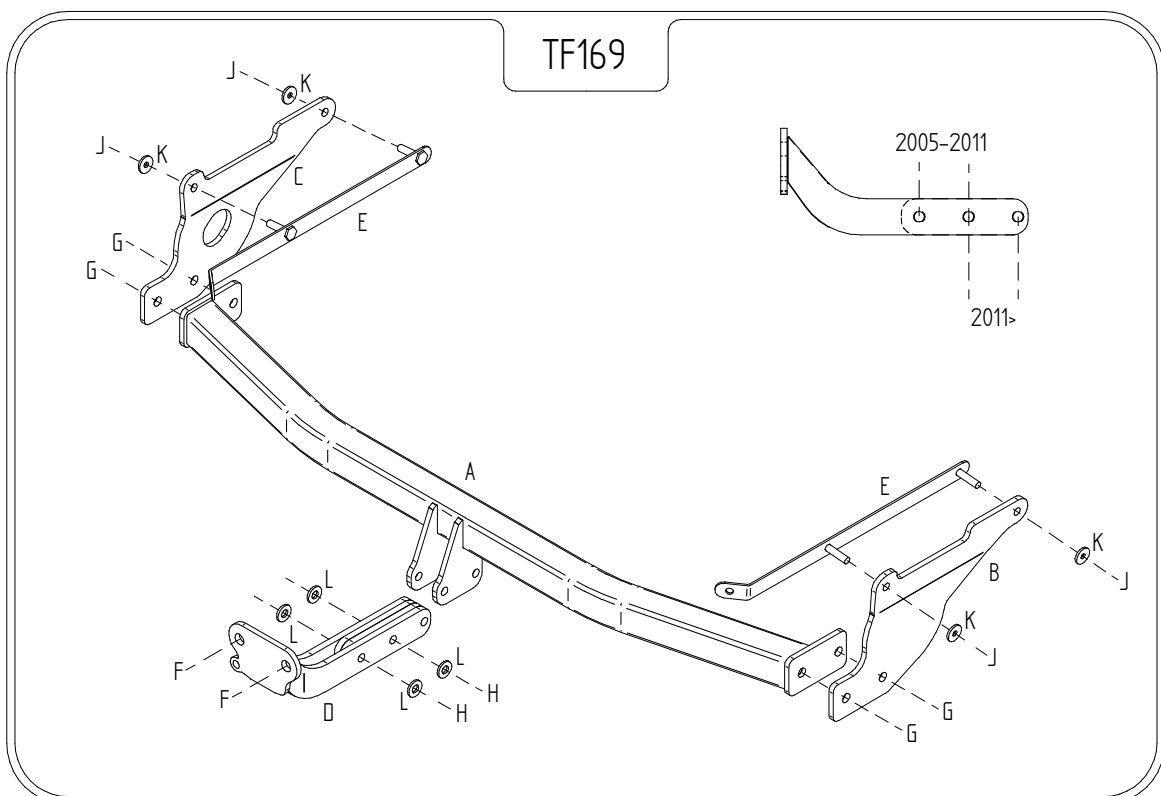

### Note:

1. Recommended Torque Setting for M12 Grade 10.9 -130 Nm. (For other Torque Settings see notes overleaf.)
2. Nose load limits and vehicle manufacturer's trailer / caravan weight limits must be observed.